

Designing a Water-Quality Monitor With Ion Selective Electrodes¹

Martin G. Buehler, Jet Propulsion Laboratory, California Institute of Technology, Martin.G.Buehler@jpl.nasa.gov
Samuel P. Kounaves, Department of Chemistry, Tufts University
Dennis P. Martin, Halcyon Microelectronics, Inc.
Steve J. West, Thermo Orion, Inc.
Gregory M. Kuhlman, Jet Propulsion Laboratory, California Institute of Technology

Abstract—This effort is directed at developing a sensor for evaluating water quality. A set of nine ion selective electrodes (ISEs) are being fabricated on a 4.5-cm diameter ceramic substrate. This paper discusses the design and fabrication of the deposition chamber and the ceramic substrates that form the basis for the ISEs. The chamber, substrate and electronics design was validated to assure that the multiplexing electronics functions, the ceramic substrate mounted is stress-free, and the deposition chamber is water tight. Results from the electrolysis of a dilute nitric acid solution are presented to further validate the design concept.

TABLE OF CONTENTS

1. INTRODUCTION
2. CERAMIC SUBSTRATE
3. DEPOSITION CHAMBER
4. DEPOSITION CHAMBER ELECTRONICS
5. EXPERIMENT VALIDATION
6. ELECTROLYSIS RESULTS
7. ION SELECTIVE ELECTRODE
8. CONCLUSION
9. REFERENCES
10. ACKNOWLEDGEMENTS
11. BIOGRAPHIES

1. INTRODUCTION

This effort is based on an ion selective electrode (ISE) array developed for the MECA (Mars Environmental Compatibility Assessment) project [1] in which 20 prefabricated ISEs were individually mounted into the walls of a 25-cm³ housing. The container was designed to be capable of analyzing the ionic content of Martian soils.

The target ions here are K⁺ (340 mg/L), Ca²⁺ (30 mg/L), Mg²⁺ (50 mg/L) and Cl⁻ (200 mg/L) representing some of

the NASA Spacecraft Maximum Contaminant Levels (MCL) for potable water for International Space Station Alpha. This is a joint effort between Tufts University, and Orion Research, Inc. who have many years of experience in the fabrication of ISEs and in water quality measurements and JPL which has experience in arraying sensors on ceramic substrates.

2. CERAMIC SUBSTRATE

The development of carrier-based polymeric membrane ISEs, whose key components are a lipophilic complexing agent (ionophore) capable of reversibly binding the analyte and a solvent polymeric membrane, has dramatically expanded the number of analytes amenable to potentiometric analysis. As seen in Figure 1 the membrane is composed of a high viscosity, water-immiscible “liquid.” With one face exposed to the sample and the other to the internal reference electrode (electrolyte), it acts as the “transducer,” converting a chemical concentration gradient into an electrical potential difference.

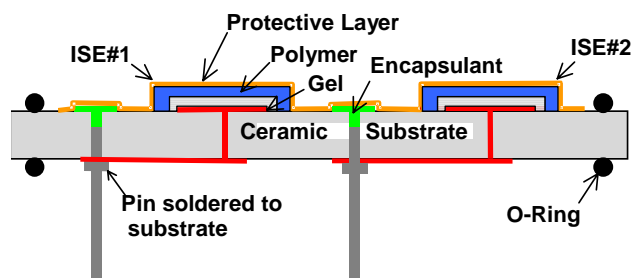

Figure 1. ISE sensor array fabricated on a ceramic substrate.

The carrier based system relies on the ionophore to control transport and generate a gradient of the analyte through the

¹ 0-7803-6599-2/01/\$10.00 © 2001 IEEE

membrane, on the other hand, the ion-exchange system takes advantage of the exchange equilibrium between the analyte ion and an ionic exchanger. The selectivity of the membrane is a result of these ion exchange equilibria. The selectivity is related to the constants of the exchange equilibrium for the analyte and interfering ions at the organic/aqueous membrane interface, and strongly depends on the ratio of the complex formation constant to the ionophore in the membrane phase.

The personalization of the ISEs uses a doping chamber that contains an electrolyte with a selected ionophore. A specific array element (electrode) is electronically selected and the desired ionic species is incorporated by electromigration and/or electropolymerization into the hydrogel layer. Then, using a new solution, the specific ionophore is incorporated into a second polymer layer. This customization process is repeated for each of the other nine ion-specific elements of the array.

The ISE substrates, shown in Figure 1, are prepared using the same technology used to fabricate hybrid microelectronic circuits on co-fired ceramic substrates [2]. In our case the substrate is a 1-mm thick 96% alumina layer with an as-fired surface. Electrical connection is achieved via 0.5-mm diameter pins soldered to the underside of the ceramic. Conducting Pd-rich Ag layers are screen printed on the ceramic and fired in air at 840°C. Conducting vias are formed by filling laser machined holes with Ag-Pd. The site of the pin is offset from the location of the ISEs. This was required to accommodate the conducting vias.

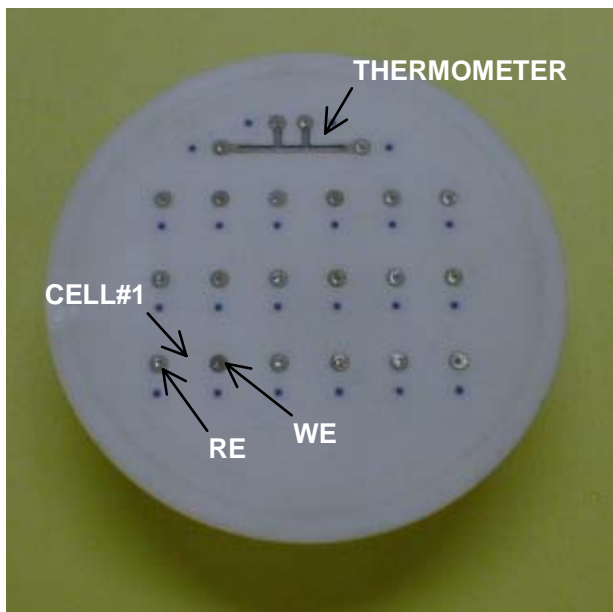

Figure 2a. Top side of a 4.5-cm diameter ceramic substrate showing the working (WE) and reference (RE) electrodes arranged on a 3 × 3 array and a four-terminal thermometer.

A top-side photograph of the 4.5-cm diameter ceramic substrate is shown in Figure 2a. The ISEs are arrayed in a 3 × 3 matrix with working electrodes (WE) and reference electrodes (RE). The WE is coated as indicated in Figure 1. The RE is basically uncoated. The thermometer is formed by screen printing RuO₂ and is used to monitor the temperature of the electrolyte during deposition.

The bottom side of the ceramic substrate is shown in Figure 2b. The electrical pins are nickel-plated stainless steel attached to the underside of the ceramic with 60/40 Sn/Pb solder with an RMA flux. As seen in Figure 1, the pins penetrate only partly into the ceramic. The top of the hole occupied by the pin is sealed with an alumina filled SiO₂ dielectric encapsulant screened printed prior to insertion of the pins.



Figure 2b. Ceramic substrate, bottom view, showing the pins used to connect to the top side electrodes through the vias.

The ceramic substrates are placed in the deposition chamber. A water-tight seal is achieved via circular O-rings seen in Figure 1. As seen in the figure two O-rings are placed on the top and bottom of the ceramic so that the ceramic does not experience tensile stresses. Such stresses could crack the ceramic. Contact to the pins is accomplished using a ZIF (Zero-Insertion Force) socket to be shown later. This too minimizes the stress on the ceramic thus reducing the chance of cracking.

3. DEPOSITION CHAMBER

Once the high temperature processing steps are complete, the gel layer is deposited via screen printing. Then the substrate is placed in the deposition chamber and

ionophores are introduced in an aqueous solution. The ionophores are deposited on the gel of a particular cell by electronically addressing the cell. Once complete, the ionophore is removed and a new ionophore introduced and directed electronically to the next cell. This process is repeated until all the cells are addressed. Then the polymer layer is deposited and the process repeated.

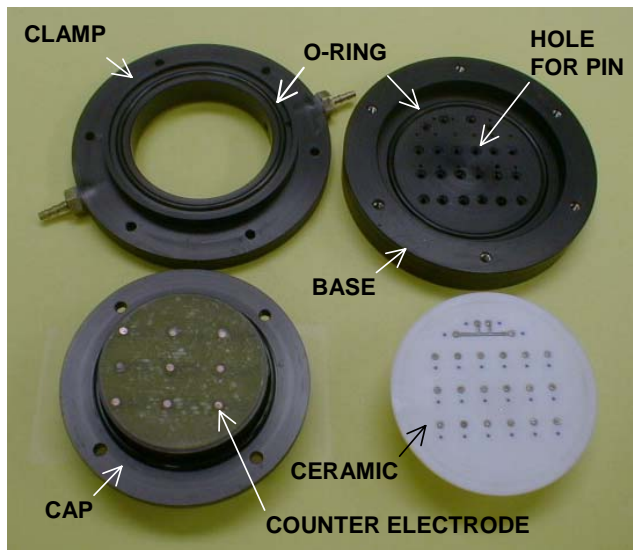

Figure 3. Deposition chamber components including the ceramic substrate (lower right) and three chamber units: Base (upper right), Clamp (upper left), and Cap (lower left). The ceramic substrate is held in place by two O-rings: one in the Base and in the Clamp.

The three parts of the deposition chamber are shown in Figure 3. One of the O-rings is shown in the Base. The other sealing O-ring is located in the underside of the Clamp. The under side of the Cap contains the counter electrode (CE) array and is sealed with an O-ring. The top of the Cap contains the connections to the CE (not shown).

4. DEPOSITION CHAMBER ELECTRONICS

Figure 4 shows the deposition chamber mounted on the electronics board. The deposition chamber is inserted into the ZIF socket mentioned above. The cable, connected to the top of the cap of the deposition chamber, is used to bring voltage to the counter electrodes.

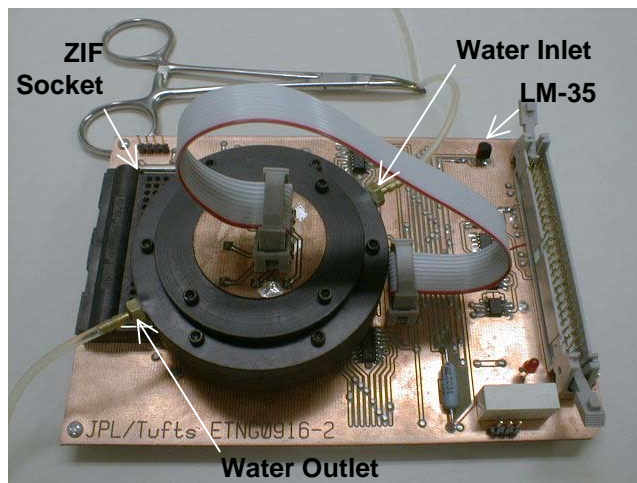

Figure 4. Deposition chamber mounted on the circuit board using a zero-insertion force (ZIF) socket.

The circuitry, shown in Figure 5, allows for deposition at the addressed cell. That is, the ionophores in the electrolyte are directed to the selected WE. In the figure, the multiplexers are symbolized by the switches. Notice that each cell has four switches that are addressed via three digital lines.

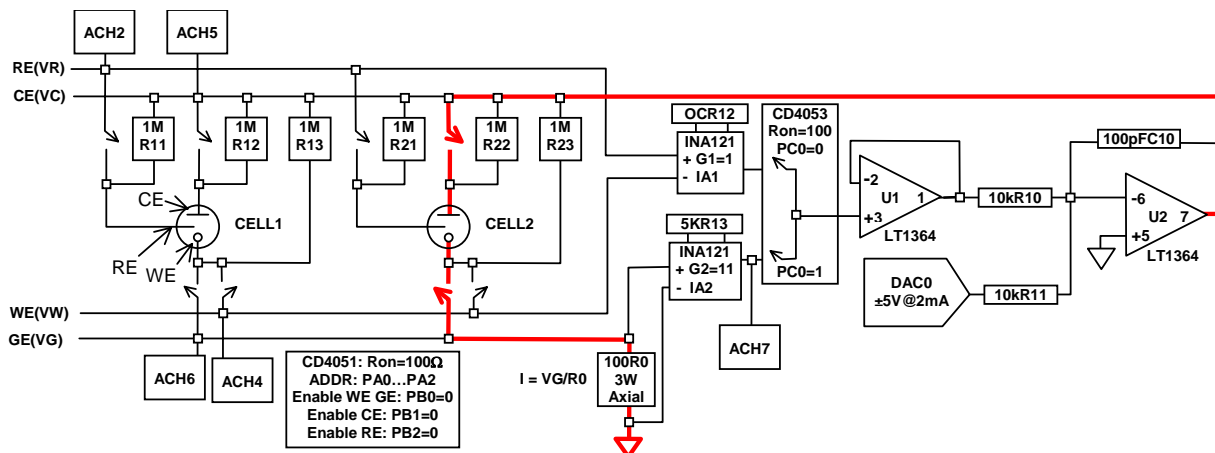

Figure 5. Deposition chamber circuitry where the digital lines PA, PB, PC, and analog lines ACH refer to DAQPad-1200 connections. Resistor values are in ohms. Ron is the MUX on resistance.

The cells can be operated in either of two modes: potentiostatic or galvanostatic. In the potentiostatic mode a constant voltage is maintained between RE and WE. In the galvanostatic mode, a constant current is maintained through each cell by measuring the voltage drop across the resistor R0.

The main current flow is indicated for Cell#2 by the red (heavy) line. The current follows through two multiplexers whose resistance is about 100 ohms each. Voltages for RE and WE are sensed at two other multiplexers. When voltages are sensed, the resistance of the multiplexers is inconsequential because the current drawn by the instrumentation amplifiers, IA's, is small so there is no voltage drop across the MUX resistor. All of elements in the array that are not addressed are tied to CE through 1 Megaohm resistors. This inhibits the deposition of the ionophores except at the selected WE. The apparatus is designed with bipolar potentials so that either positively or negatively charged ionophores can be deposited.

5. EXPERIMENT VALIDATION

When developing one-of-a-kind equipment, it is important to provide numerous checks to determine that the equipment is operating properly. This apparatus has four checks to help in problem solving.

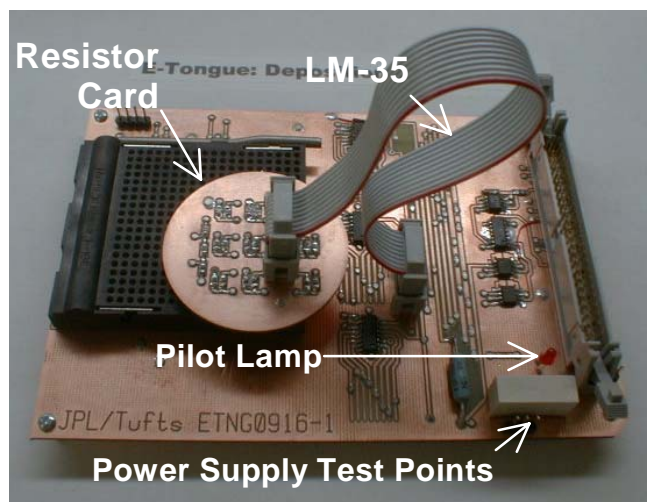

Figure 6. Resistor card mounted on the deposition chamber circuit board.

First, the pilot lamp indicates that power is being delivered to the board via the 50-pin connector attached to the National Instruments DAQPad-1200. Second, the on-board thermometer is useful to verify that analog signals are being acquired by the DAQPad-1200 and transmitted to the computer. The verification takes place by placing a finger on the thermometer (LM35 visible in Figure 4) and

observing the increase in temperature. Third, the $\pm 5V$ power supply test points are used to further diagnose problems.

Fourth, the resistor card seen in Figure 6 is used to verify that the multiplexer addressing is correct. The resistor card is fabricated with an array of resistors that are different for each cell. When voltage is applied to the array, a unique voltage is produced for each cell and this is used to verify the correctness of the addressing circuitry and software.

6. ELECTROLYSIS RESULTS

A series of electrolysis tests were undertaken to further demonstrate that the apparatus is functioning properly. Before starting the electrolysis test, it was determined that the chamber was water tight and that the ceramic substrate was not broken when mounted in the chamber and inserted in the ZIF socket. This verified that the dual O-ring design was correct.

Next, an electrolysis test was performed to show that the cells, chamber and electronics function properly with aqueous solutions. As seen in Figure 7, a dilute solution of nitric acid was used which ranged from 0.01 to 14 mM. Measurements were taken in potentiostatic mode where the voltage, $V(WE - RE)$, was varied from -0.8 to +0.8 volts.

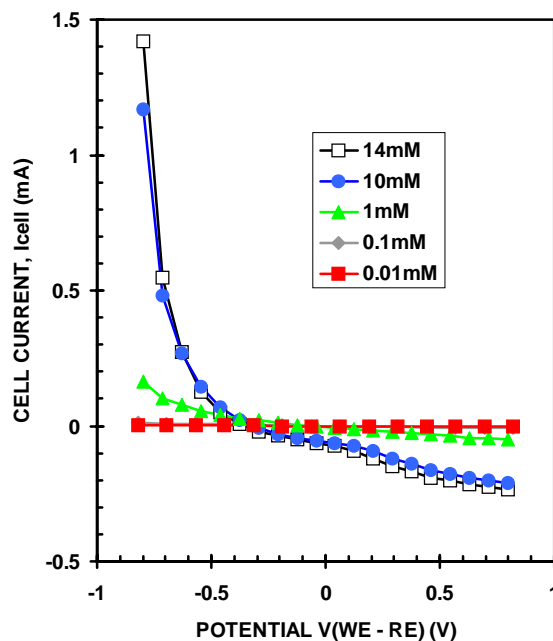

Figure 7. Potentiostatic response of Cell#1 to a number of nitric acid solutions ranging from 0.01 to 14 mM.

The results in Figure 7 show the response of Cell#1 to various concentrations of nitric acid. The dramatic increase in cell current, I_{cell} , at -0.7 V is expected and indicative of hydrogen generation in the cell at the Pd-Ag working electrode. A curve similar to Figure 7 appears elsewhere [4.3] for a 100 mM HCl solution using a mercury drop electrode.

The curve in Figure 8 shows the response is linear at low concentrations but is nonlinear at higher concentrations. This effect is expected. The role off of the response at higher nitric acid concentrations is due to hydrogen generation at the working electrode reducing the electrode area.

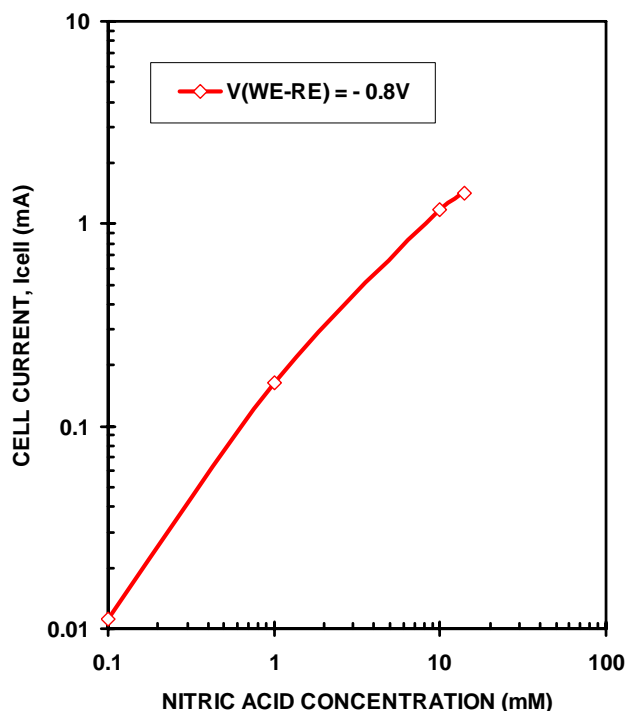

Figure 8. Response of Cell#1 at potential of -0.8 V.

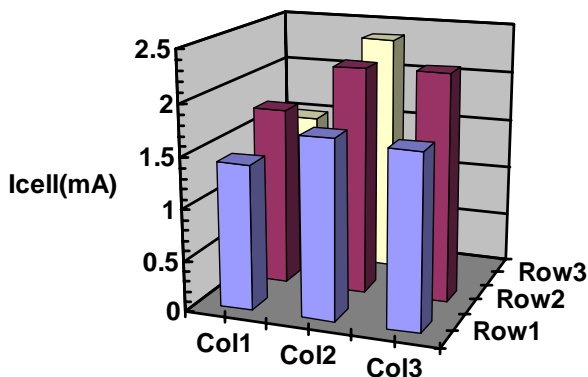

Figure 9. Response of array at $V(WE - RE) = -0.08$ V where the mean is 1.86 ± 0.36 mA.

Finally, the response of the array is shown in the histogram in Figure 9 where the I_{cell} data was measured at $V(WE-RE) = -0.8$ V. The profile indicates that the response is non-uniform across the substrate. This is most likely due to small variations in electrode area that causes perturbations in the steep portion of the curve shown in Figure 7.

7. ION SELECTIVE ELECTRODE

The goal of this effort is to develop a space-qualified water quality monitor. The type of response that is desired is shown in Figure 10. This response was taken using a series of ISEs. The Li^+ and Na^+ ISEs are duplicates of those used in the MECA cup. The other ISEs are Orion production models. Anionic ISEs have a negative voltage response with increasing concentration and cationic ones a positive. As can be seen, ISEs have a broad dynamic response, usually over 5 orders of magnitude.

Figure 10 shows the selectivity of the ISEs. In this case the ISEs were placed one at a time in a multi-analyte solution containing $1e^{-5}M$ of $KHCO_3$, NH_4NO_3 , $NaCl$, $CaCl_2$, and $MgCl_2$, and $2.5e^{-3}M$ of Li_2SO_4 . For this mixture, each ion was calibrated minus it's own ion. That is, the Li^+ ISE was calibrated in the presence of all the above ions except Li^+ . Only the perchlorate ISE was calibrated by itself in de-ionized water. All ISEs were calibrated with a primary ion concentration ranging from 1M to $1e^{-6}M$. Serial dilutions were performed using a 1M stock of each solution to the desired concentration. The calibration was performed using several beakers containing the range of primary ion to be monitored. Stock solutions of the other leaching solution components were added to each solution so the proper background of $1e^{-5}M$ or $2.5e^{-3}M$ would be maintained in relation to the primary ion.

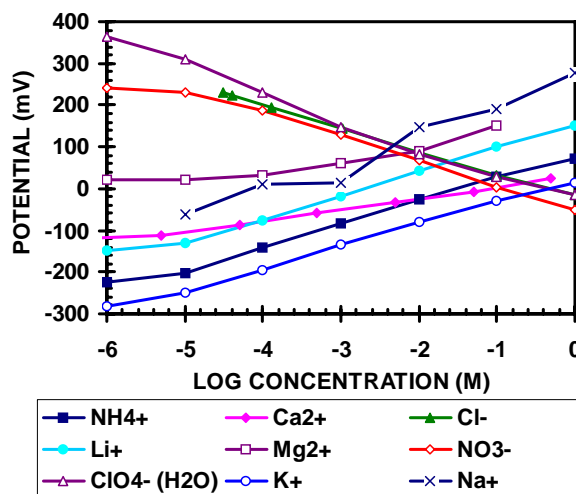

Figure 10. Typical ISE response to nine ions dissolved in multi-analyte solution described in the text.

8. CONCLUSION

This paper describes the numerous design issues involved in the developing and integrated ISE-based water quality monitor. In this effort nine ISEs are arrayed on a ceramic substrate. As described in the paper, precautions were taken to minimize the stress on the ceramic substrates by using a dual balanced O-ring approach and ZIF sockets. Both of these approaches were successful in preventing cracking of the ceramic substrate when mounted in the deposition chamber. In addition, the O-rings provide a water tight seal. The array is addressed using multiplexers which allow sharing the drive and measuring electronics.

The chamber was exercised by electrolyzing a dilute solution of nitric acid. It was shown that the cells exhibit a "turn-on" of about - 0.7 V that is due to hydrogen formation. In addition, the response across the electrode array was measured and the deviation was within 20 percent. In the future, these measurements may form the initial test sequence used to qualify newly fabricated substrates.

In the coming months, the ISE arrays will be fabricated and personalized using electromigration and/or electropolymerization methods. Then this effort will be directed at enhancing ISE detection sensitivity and lifetime.

9. REFERENCES

- [1] S. J. West, X. Wen, R. Geis, J. Herdan, T. Gillette, M. H. Hecht, W. Schubert, S. Grannan, S. P. Kounaves, "Electrochemistry on Mars," *American Laboratory* 31 (20), p. 48-, Oct. 1999
- [2] R. J. Hannemann, *Semiconductor Packaging: A Multidisciplinary Approach*, J. Wiley (New York, 1994).
- [3] D. A. Skoog and J. J. Leary, *Principles of Instrumental Analysis*, Harcourt Brace College Publishers (Forth Worth, 1992), p. 552.

10. ACKNOWLEDGMENTS

The work described in this paper was performed by the Jet Propulsion Laboratory, California Institute of Technology, under a contract with the National Aeronautics and Space Administration. The overall effort is supported by a grant from the National Aeronautics and Space Administration under the Advanced Environmental Monitoring and Control Program. The authors are indebted to our program manager, Darrell Jan, for his support. In addition the authors acknowledge the contribution of Kimberly

Kuhlman in suggesting the ISE deposition concept which has lead to the filing of a patent. File: EtngAero0C28.doc.

11. BIOGRAPHIES

Martin G. Buehler received the BSEE and MSEE from Duke University in 1961 and 1963, respectively and the Ph.D. in EE from Stanford University in 1966 specializing in Solid State Electronics. He worked at Texas Instruments for six years, at National Bureau of Standards (now NIST) for eight years, and since 1981 has been at the Jet Propulsion Laboratory where he is a senior research scientist. At JPL he has developed p-FET radiation monitors for CRRES, Clementine, TELSTAR and STRV, E-nose which flew on STS-95, and an electrometer for the Mars '01 robot arm. Currently he serves on the staff of the New Millennium Program as a technical analyst. Martin is a member of the IEEE, Tau Beta Pi, and Sigma Nu. He holds 12 patents and has published over one hundred papers.

Samuel P. Kounaves received his BS/MS from Cal State - San Diego in 1976/78 and his Ph.D. (D.Sc.) from the University of Geneva in Switzerland in 1985. After a post-doctoral fellowships at SUNY-Buffalo and Harvard University he joined the faculty at Tufts University in 1988, where he is currently an Associate Professor of Chemistry. He has an active research group of 8 Ph.D. students and one undergraduate. He has been a principal investigator on more than 15 grants from government (NSF, EPA, DOE) and industry (PRF, EG&G, Orion). He has authored over 50 publications and holds 3 Patents. His research has been directed at the development of microfabricated electrochemical and chemically modified sensors, for use in monitoring and investigation of remote hostile environments, especially planetary bodies. Most recently he has been involved with NASA's Jet Propulsion Laboratory to include several sensor arrays on the next Mars Lander for performing chemical analysis of the Martian soil.

Dennis P. Martin received his BSME from California State Polytechnic University in 1976 and pursued graduate work in Material Sciences of Microelectronics at Arizona State, California Institute of Technology, and University of Florida. Dennis joined the Jet Propulsion Laboratory and in 1981 formed Halcyon Microelectronics, Inc. As president of Halcyon Microelectronics, Dennis heads up the advanced packaging for research and development with emphasis on miniaturization of complex systems for hostile environments; i.e., high radiation, high "g" force, and extreme temperature. Halcyon offers a laboratory in which products are developed. More than 300 designs have become working prototypes for customers ranging from the

California Institute of Technology and Rockwell International to MIT and Cree Research. In the last five years, Mr. Martin has expanded Halcyon's role as a service laboratory for package research and development into sensor development. He is a member of ISHM.

Steven J. West: Steve received a B.S. in Chemistry from Bates College in Lewiston, ME, did graduate work in chemistry at Northeastern University, Boston, MA, and research at the Department of Organic Chemistry, Swiss Federal Institute of Technology, Zürich Switzerland. Steve worked as an analytical chemist for Kennecott Copper Corporation before joining Thermo Orion in 1974 as a research chemist. Steve's principal areas of expertise are in aqueous solution chemistry, electrochemistry, conventional and microfabricated chemical sensors, analytical separations, and spectrophotometry. He has served as manager of Contract R&D, Process Instrument Engineering and is presently Vice President of Research at Thermo Orion.

Gregory M. Kuhlman: Greg received a B.S. degree in Bacteriology from the University of Wisconsin-Madison in 1995. Following graduation Greg has worked for the University of Wisconsin-Madison, Covance Laboratories Incorporated, and Amgen Incorporated before coming to the Jet Propulsion Laboratory (JPL) in 2000. Greg's skills include classical bacteriology techniques, modern molecular biology techniques and extensive protein chemistry skills. Greg has mastered most modern chromatographic techniques such as High Pressure Liquid Chromatography (HPLC), Fast Protein Liquid Chromatography (FPLC) and Capillary Zone Electrophoresis (CZE). As an undergraduate at the University of Wisconsin-Madison Greg worked in the lab of Dr. Eric Johnson, world renown researcher of *clostridium botulinum* and other food borne pathogens, and has acquired the skills for working with pathogenic microorganisms. At JPL Greg focuses his time between two groups. He works with the Planetary Protection Technologies Group where he is researching and evaluating advanced technologies for molecular detection of microbes on spacecraft materials and in spacecraft assembly facilities. Greg also works with the Microdevices Laboratory where he is utilizing his biology skill set to test and study the effects of biofilms on space flight hardware.